

# eSync

*Portable hydraulic multi-point motion control system*  
Synchronous lifting/lowering, or pushing/pulling for heavy objects.



# PORTABLE AND EXPANDABLE MOTION CONTROL SYSTEM

## eSync Hydraulic Synchronous Lifting/Lowering Solution

The Power Team eSync portable synchronous system is a combination of digital actuation and digital control. The Microprocessor-controlled eSync is a high accuracy solution to lift or lower an object within a tight tolerance. Synchronous lifting helps to eliminate unwanted stress on the object while the eSync standard features offer the ultimate in user and object safety.

eSync is an economical direct replacement for multi-point motion control systems or split flow pumps.

The eSync utilizes a 4-point light-weight platform, linkable to 16 eSync units and 64 points.

Easily transport the system to the job site with the eSync compact portable package that breaks down into 3 easy to carry sections (eSync, Pump, Storage). This allows a two-man carry to the lifting zone to position the eSync with the included uCage modular stackable workstation, simply stack and quick-pin to create the synchronous tower.

For the ultimate in portability or remote projects choose the battery powered complete system from hydraulic pump to eSync motion control or select from your choice of voltages that fit your requirement.

whether it is a bridge, a building, or any kind of heavy load, with the Power Team eSync, lifting, lowering, pushing, pulling, or positioning loads can be carried out automatically with a high degree of accuracy.



# eSync KEY FEATURES

Interface allows quick access to menus for user inputs and monitoring lift performance. Microprocessor control includes real-time display, synchronous position control, manual operation, data-logging, valve timing, system linking, unit selection, and system warnings for auto shutdown.

Cordless 60VDC battery system and 115VAC or 230VAC powered options.

USB for data-logging synchronous lifts for post review.

E-Stop for quick connected pump and valve actuation shutdown in an emergency.

Pressure transducer for digital system pressure readout.

Feedback sensors allow controlling the accuracy between all points within a 1mm tolerance.

Pendant controls synchronous/manual toggle, advance/retract, and synchronous stop.

Standard link option for connecting multiple units together creating a larger multi-point eSync system.

Millisecond adjustable electrically controlled valves meter the distribution of oil into the hydraulic circuits for increased accuracy.

Load lowering valve controls the descent of a heavy object, adding another level of safety during the lowering process.

Adjustable relief valves allow for user control of the advance and retract fluid pressure.

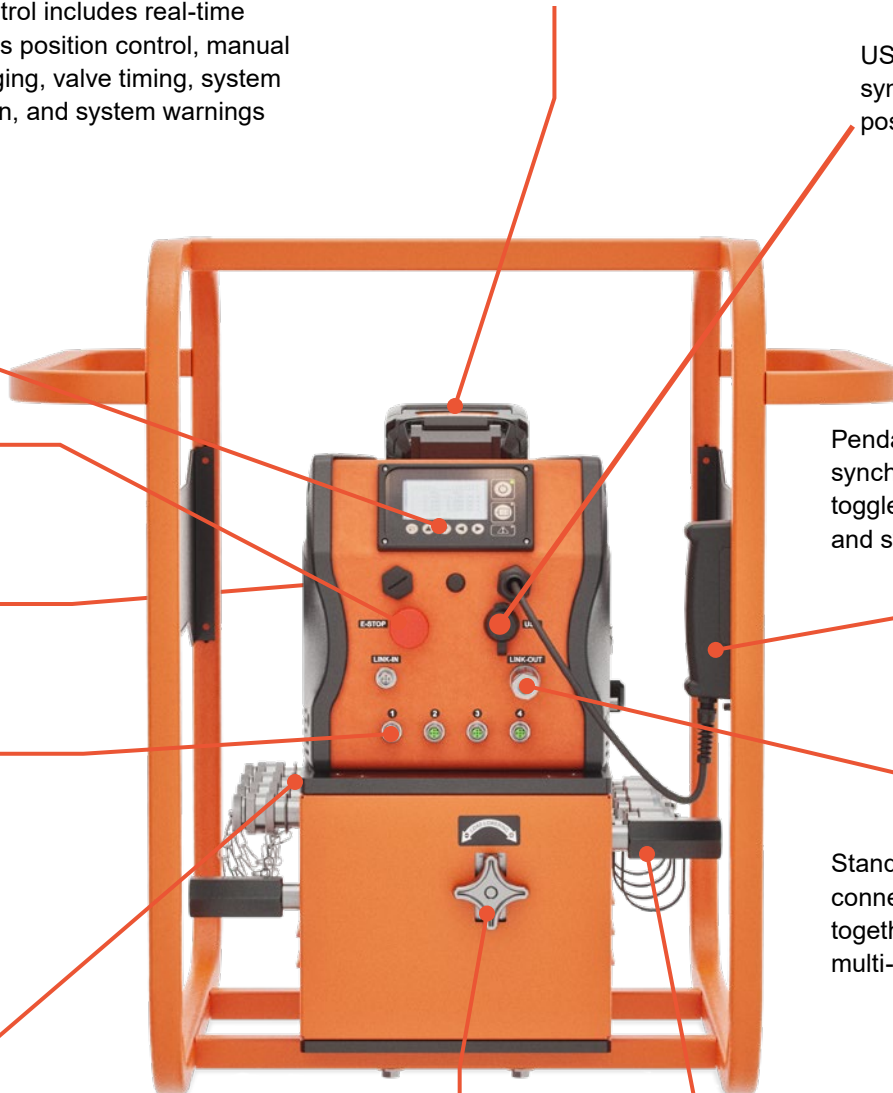

# PB43 (Cordless) AND PE55 (Corded) HYDRAULIC PUMPS

PB43 cordless 60VDC battery system featuring a Li-ion 60VDC, 8.0 Ah battery with 4 level battery life indicator, 1.5 Hour battery charge time from drained to full. Battery chargers available in 115VAC 60HZ and 220AC 50HZ options. PE55 corded pumps available in 115VAC or 230VAC powered options.

Ergonomic 2-person carrying handle on cage for maximum comfort.

Weatherproof ratings:  
Pump rated: IPX4

Plug and play manifold – easy hose connection.

Industry leading, field proven, Power Team Vanguard Pump technology.

Lightweight and portable.  
Great performance-to-weight ratio.

Cordless PB43 3.0 gallon hydraulic oil reservoir with sight gauge. Corded PE55 2.5 gallon hydraulic oil reservoir.

Two-stage, high-pressure (10k PSI) hydraulic pump offers unloading valve that achieves greater pump efficiency with quick tool advancement in the first stage, while shifting to high pressure second stage when demanded.

Easy access hydraulic fluid drain port.

Protective and stackable uCage comes standard with PE55 or PB43 hydraulic pumps.



# uCage & ADDITIONAL FEATURES

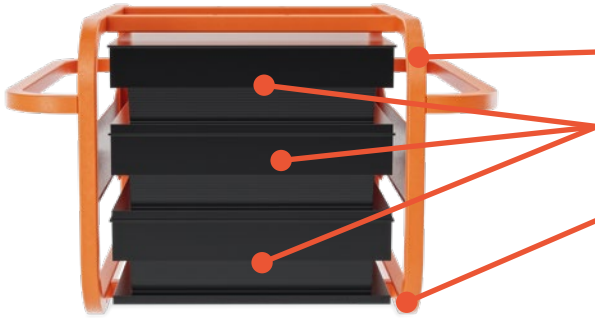

Protective and stackable uCage comes standard for the eSync, storage totes, and hydraulic pump.

Three on-board stackable totes allow protection and storage of position sensors and cables.

Lock-in-place design with secure strap for hassle-free transportation.



Handheld pendant controls the auto and manual functions allowing a remote position for better visual operation with included storage holster.

Pendant controls auto synchronous/manual toggle, advance/retract, and stop operation for safety situations that require a quick override.

Ergonomic IP55 rated remote pendant with 12 ft / 3.6m cord and large button design.

Pendant buttons require low finger depression force to operate for decreased operator fatigue.

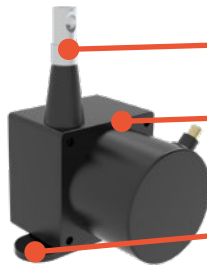

39.4" (1000mm) linear position sensors give feedback to the Microprocessor for load location.

Position sensors allow synchronous movement accuracy to .040" (1mm).

Linear position sensors include magnet kit to mount to load or cylinder.



Li-ion 60VDC, 8.0 Ah battery with 4 level battery life indicator.

1.5 Hour battery charge time from drained to full.

Charger available in 115VAC 60HZ or 230VAC 50HZ.

Global battery compatible with both charger styles.

# eSync TECHNICAL INFORMATION

## Features

eSync includes 4 standard double acting hydraulic points, linkable to 16 eSync units and 64 points.

Systems can be completely cordless for reliable remote operation or corded when power is available.

eSync units are available without a pump or included with Power Team PB43 (cordless) or PE55 (corded) hydraulic 10K PSI pumps.

Systems that include a pump come with everything you need to get started. Just add cylinders and hydraulic hoses for a complete system ready to lift.

eSync battery supplies hours of continuous run time based on demand with 1 fully charged 8ah battery.

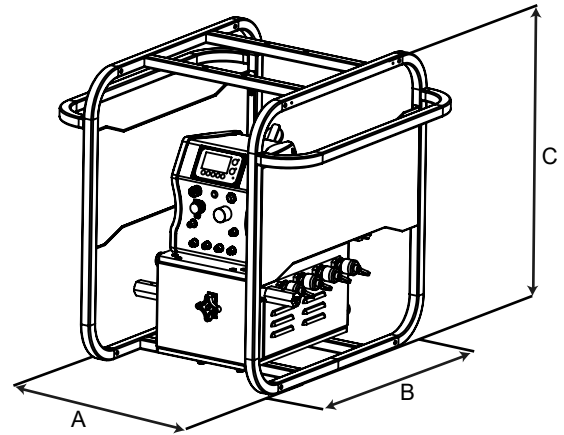

Order No.	With uCage in/(mm)				Pump Included	Voltage	Battery/Charger Included	Sensors / Transducers Included	**Weight lb (kg)		
	A	B	C	Total Height							
ES14PRTXA	19.0 (482.6)	27.0 (685.8)	27.0 (685.8)	44.0 (1117.6) includes totes uCage	N/A	115VAC 60HZ	N/A	(1) System pressure transducer & (4) linear position sensors	130 (59)		
ES24PRTXA						230VAC 50/60HZ					
ES64PRTYXA						60VDC 8Ah				115VAC 50/60HZ Charger	
ES64PRTZXA										230VAC 50/60HZ Charger EU Plug	
ES64PRTWXA										230VAC 50/60HZ Charger UK Plug	
ES64PRTXXA										230VAC 50/60HZ Charger AU Plug	
ES14PRTXD				71.0 (1803.4) includes totes and pump uCage		PE551MX2 hydraulic pump	115VAC 60HZ		N/A	261 (118.4)	
ES24PRTXD						PE552MX2 hydraulic pump	230VAC 50/60HZ				
ES64PRTYXB						PB43MX2-1 hydraulic pump	60VDC 8Ah				115VAC 50/60HZ Charger
ES64PRTZXB						PB43MX2-2 hydraulic pump					230VAC 50/60HZ Charger EU Plug
ES64PRTWXB						PB43MX2-3 hydraulic pump					230VAC 50/60HZ Charger UK Plug
ES64PRTXXB						PB43MX2-4 hydraulic pump					230VAC 50/60HZ Charger AU Plug
								269 (122.0)			

\*ESYNC WEIGHT: WITH UCAGE

## Safety features

full stop due to power failure, sensor failure, tolerance error, linked connection, time out and many more control and pendant warnings.

Protective and stackable uCage elevates the control height for improved operation and the overhead totes offer sun protection that improve display visibility.

Lightweight modular design allows for two-person carry for easy transport, setup, and teardown.



# PUMP TECHNICAL INFORMATION

## Battery version features

30 Minutes continuous run time with PB43 hydraulic pump based on demand.

The 60-volt battery powered motor in the PB43 offers increased power that delivers industry leading pump flow performance.

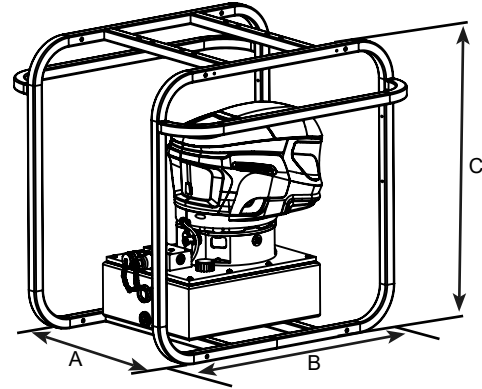

ABOVE: PB43 w/ uCage

Order No.	With uCage in/(mm)			Voltage	Pendant	9500 Valve	Battery/Charger Included	RPM	dBA Idle/ Max Press.	Oil Delivery - l/min (cu.in/min) @			*Wt lbs (kg)							
	A	B	C							7 Bar (100 psi)	350 Bar (5k psi)	700 Bar (10k psi)								
PE551MX2	19.0 (482.6)	27.0 (685.8)	27.0 (685.8)	115VAC 60HZ	No	N/A	115VAC 50/60HZ Charger	12k	83/91	11.5 (700)	1.2 (70)	1.0 (60)	131 (59.4)							
PE551MA2PE					Yes															
PE552MX2				230VAC 50/60HZ	No															
PE552MA2PE					Yes															
PB43MX2-1				60VDC 8Ah	No									*230VAC 50/60HZ Charger EU Plug	3.1k	73/75	7.8 (480)	1.2 (70)	0.7 (43)	137 (62.1)
PB43MA2PE-1					Yes															
PB432MX2-2					No															
PB43MA2PE-2					Yes															
PB43MX2-3					No															
PB43MA2PE-3					Yes															
PB43MX2-4					No															
PB43MA2PE-4					Yes															

\*PUMP WEIGHT: FILLED WITH OIL INCLUDING UCAGE

## Accessories

Accessory Part #	Description
3001434	LINKING CABLE 100' ASSEMBLY - ALLOWS CONNECTION OF MULTIPLE eSYNC UNITS
2010995	BATTERY CHARGER 115V US PLUG
2011156	BATTERY CHARGER 230V CE EU PLUG
3001464	BATTERY CHARGER 230V CE UK PLUG
3001465	BATTERY CHARGER 230V CE AU PLUG
2010994	BATTERY 60VDC 8ah

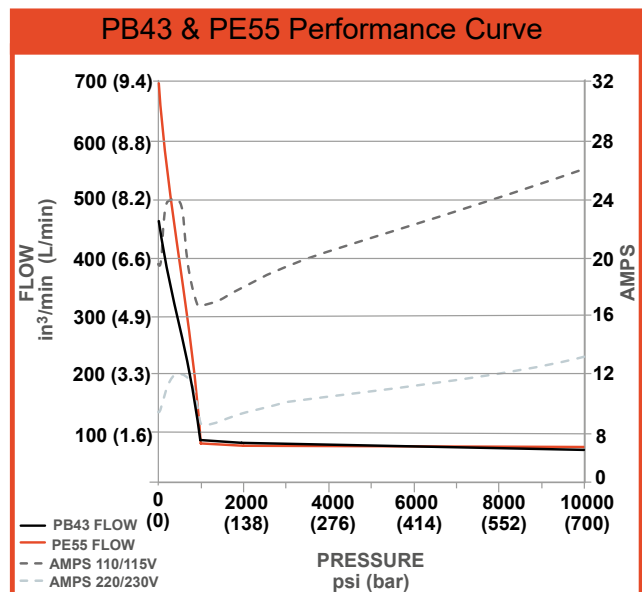

## CUSTOMER SERVICE CENTERS

### Americas

Tel: +1 800 541 1418  
info.amer@hytec.com

### Europe

Tel: +31 45 567 8877  
info.emea@hytec.com

### Bolting Rental

Tel: 1-713-472-2500 (Pasadena, TX)  
Tel: 1-361-445-3727 (Corpus Christi, TX)  
Tel: 1-225-774-0888 (Gonzales, LA)  
bolting.amer@hytec.com

### Rail Systems

Tel: +44 208 526 7100  
info.rail@hytec.com

### Asia Pacific

Tel: +86-21-67150078 (China)  
Tel: +61 03 6164 7933 (Australia)  
Tel: +65 6264 4366 (Singapore)  
info.apac@hytec.com

### Bolting Rental

Tel: +65 6264 4366  
bolting.apac@hytec.com



SCAN THE QR CODE TO WATCH THE VIDEO

Distributed by:



Hydraulic Technologies, reserves the right to incorporate our latest design and material changes without notice or obligation. Design features, materials of construction and dimensional data, as described in this bulletin, are provided for your information only and should not be relied upon unless confirmed in writing. Please contact your local sales representative for product availability in your region. For more information, visit [www.hydraulictechnologies.com](http://www.hydraulictechnologies.com)