

**TORQUE**<sup>TM</sup>

**THE RIGHT  
TOOL FOR  
THE JOB**

**VTR-CLK**



**CENTER  
OF ATTENTION**

**VTR CENTER LOCK WRENCH**

# VTR- CLK

## BATTERY - POWERED CENTER LOCK TORQUE WRENCH STRAIGHTFORWARD. ACCURATE. ERGONOMIC.

MASTER CENTER LOCK WHEEL CHANGES EFFORTLESSLY AND QUICKLY WITH OUR SMOOTH, ACCURATE AND DURABLE TORQUE WRENCH.

- CUSTOM REACTION ARM FEATURES A DELRIN® SLEEVE TO PROTECT THE WHEEL AND FITS RIM DESIGNS WITH 3IN/7.62CM OR MORE OPENING
- PROGRAMMED TORQUE SETTINGS RANGE FROM 200FT-LBS/300NM TO 1000FT-LBS/1360NM TO MEET VEHICLE SPECIFIC TORQUE REQUIREMENTS\*\*
- UP TO 1000FT-LBS/1360NM TORQUE POWER TO EASILY REMOVE ANY OVER TORQUED CENTER LOCK NUTS\*\*
- ELIMINATES THE NEED FOR A MANUAL CLICKER WRENCH, HAND TORQUE MULTIPLIER OR TWO-PERSON OPERATION
- BATTERY FULLY CHARGED IN UNDER 60 MINUTES
- CARRYING CASE FOR STORAGE AND TRANSPORT



\*\*Always refer to the specific vehicle manufacturer's recommendations for torque settings and wheel change procedure, as well as utilize the correct center lock adapter supplied by the vehicle manufacturer.



MODEL NUMBER	VTR-1000-.75 W/ REACTION ARM
SQUARE DRIVE	3/4"
MIN. TORQUE (LBF-FT)	200
MAX TORQUE (LBF-FT)	1000
MIN. TORQUE (NM)	300
MAX TORQUE (NM)	1360
WEIGHT (LBS)	14.9
WEIGHT (KG)	6.8
MIN. RPM TORQUE	6
MAX RPM TORQUE	8.75

\*Reference values only. ISO 17025 accredited calibration standard.

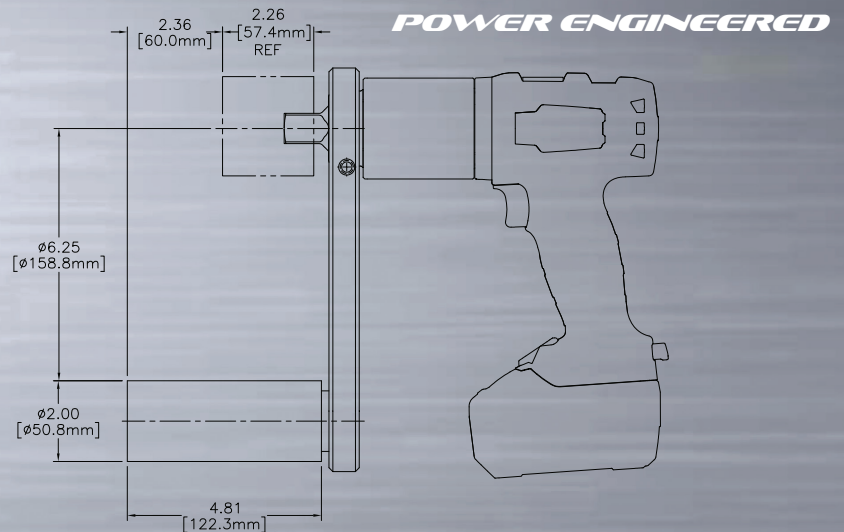

TOLL FREE: 1-888-TORCUP-1  
TELEPHONE: 1-610-250-5800

FAX: 1-610-250-2700  
EMAIL: SALES@TORCUP.COM



TorcUP Inc. 1025 Conroy Place Easton, PA. 18040 USA | [www.torcup.com](http://www.torcup.com)

TorcUP products are subject to continual development and TorcUP reserves the right to make changes to the specifications and design of their products without prior notice. All rights are reserved. Reproduction in whole or in part without permission of TorcUP Inc. is prohibited.