



torquid

**A TOOL WITH
MULTIPLE PERSONALITIES**

TX LOW PROFILE TORQUE WRENCH

TX

LOW PROFILE HYDRAULIC TORQUE WRENCH

THE WRENCH WITH VERSATILITY

THE WORLD'S MOST CHALLENGING BOLTING JOBS REQUIRE A HYDRAULIC TORQUE WRENCH THAT CAN GO "FLAT OUT." APPLICATIONS WITH RESTRICTIONS ABOVE, AROUND AND BEHIND THE NUT DEMAND A TOOL THAT CAN GET FLAT AND GET ON THE JOB. THE TX SERIES WAS THE FIRST FLAT HYDRAULIC WRENCH TO CONQUER ALL LIMITATIONS ... AND THEN SOME!!

INDUSTRY NOT ONLY REQUIRES A TOOL THAT GETS IN ... BUT ONE THAT WORKS BEYOND THE JOB-SITE EXPECTATION. WITH 20 YEARS OF PROVEN SUCCESS IN THE HARSHTEST ENVIRONMENTS, THE ONLY WRENCH TRULY CAPABLE OF GOING "FLAT OUT" IS THE TORCUP TX SERIES.



THE POWER INSIDE

1. PATENTED "PEANUT-SHAPED" CYLINDER
2. ENGAGEMENT ROD
3. NEVER-LOCK DRIVE PAWL
4. MULTI-TOOTH RATCHET
5. ONE PIECE DRIVE PLATE
6. LINK PIN
7. IN-LINE REACTION PAD
8. STEEL ALIGNMENT PIN
9. COMPLETELY FLAT DESIGN
10. 360° X 360° SWIVEL
11. PROPRIETARY PISTON SEAL
12. SLIDER PREVENTS WEAR OF PISTON

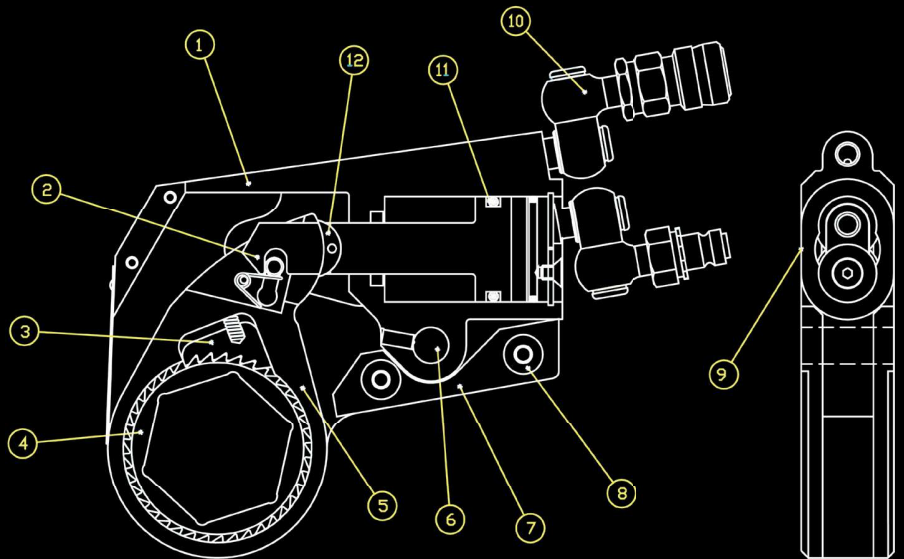

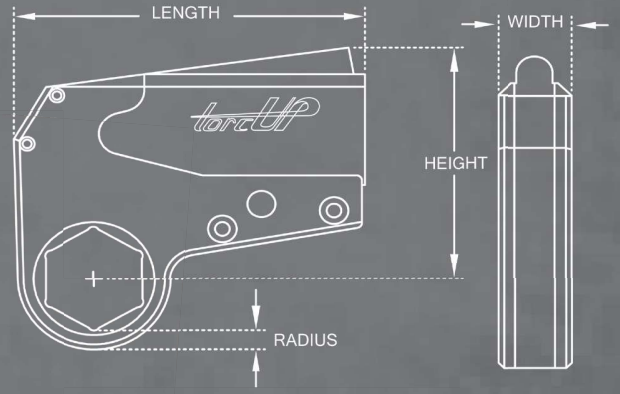

WWW.TORCUP.COM

POWER ENGINEERED

MODEL NUMBER	TX-1	TX-2	TX-4	TX-8	TX-16	TX-32	TX-45
MIN. TORQUE (lbf-ft)*	45	192	395	830	1560	3220	4850
MAX. TORQUE (lbf-ft)*	560	1928	3950	8630	16600	35650	47380
MIN. TORQUE (nm)*	61	260	535	1125	2115	4365	6575
MAX. TORQUE (nm)*	759	2614	5355	11699	22503	48327	64239
OUTPUT ACCURACY	+/-3%	+/-3%	+/-3%	+/-3%	+/-3%	+/-3%	+/-3%
REPEATABILITY	100%	100%	100%	100%	100%	100%	100%
DUTY CYCLE	100%	100%	100%	100%	100%	100%	100%
CYLINDER WEIGHT (lbs)	1.0	3.5	6.0	11.7	16.0	26.0	29.0
CYLINDER WEIGHT (kgs)	0.5	1.6	2.7	5.0	7.3	11.5	13.0
LINK WEIGHT FROM (lbs)	1.0	2.4	5.4	11.9	21.0	29.0	29.0
LINK WEIGHT TO (lbs)	1.0	3.5	7.6	14.5	28.0	39.5	39.5
LINK WEIGHT FROM (kgs)	0.45	1.0	2.4	5.5	9.5	13.0	13.0
LINK WEIGHT TO (kgs)	0.45	1.5	3.4	6.5	13.0	17.9	17.9
LENGTH (in)	4.37	6.45	7.87	10.18	12.93	15.80	16.75
LENGTH (mm)	111.0	163.8	199.9	258.6	328.4	401.3	425.5
WIDTH (in)	0.78	1.25	1.63	2.05	2.50	3.24	4.88
WIDTH (mm)	19.8	31.8	41.4	52.1	63.5	82.3	124.0
RADIUS RANGE FROM (in)	0.24	0.37	0.41	0.56	0.68	0.96	0.96
RADIUS RANGE TO (in)	0.45	0.59	0.77	0.93	1.68	1.82	1.82
RADIUS RANGE FROM (mm)	6.2	9.6	10.5	14.2	17.1	24.3	24.3
RADIUS RANGE TO (mm)	11.4	15.0	18.7	21.0	25.9	44.2	44.2
HEIGHT (in)	3.25	4.0	5.6	7.0	7.58	9.5	10.28
HEIGHT (mm)	82.6	101.6	142.2	177.8	192.5	241.3	261.1
HEX RANGE FROM	1/2"/13mm	3/4"/19mm	1"/27mm	1 7/8"/49mm	2 3/16"/55mm	3 1/8"/80mm	3 1/8"/80mm
HEX RANGE TO	2"/50mm	2 9/16"/65mm	3 1/8"/80mm	4 5/8"/120mm	5 5/16"/135mm	7 7/8"/200mm	7 7/8"/200mm

*Reference values only. Consult calibration torque chart provided with tool.



TX SERIES LOW PROFILE HYDRAULIC TORQUE WRENCH

FLAT - ACCESS THE INACCESSIBLE
PROVEN - USED ON JOB-SITES WORLDWIDE
SUPERIOR - AIRCRAFT QUALITY ALLOY

LOW POINT
REACTION PADDLE



CLOSED SPANNER
WRENCH



INLINE
REACTION
ARM



HEX TO SQUARE
DRIVE ADAPTOR



TOOL HANDLE



HEX REDUCER



Worldwide Headquarters

1025 Conroy Place
Easton, PA 18040 USA
TOLL FREE: 1-888-TorcUP-1
TELEPHONE: 1-610-250-5800
FAX: 1-610-250-2700
www.torcup.com



TX SERIES

Made In USA

Seven Models From 45 lbf-ft to
47,380 lbf-ft

Every Unit Calibrated In
ISO17025 Laboratory

Manufactured With AQ
Certified Alloys

Genuine TorcUP Design

CARRYING
CASE

